

D.zero²

Street Sweeper - us



DULEVO
FAYAT GROUP

TIMELESS QUALITY THROUGH PASSION



The evolution of all-electric sweeping

The third-generation D.Zero², with its remarkable manoeuvrability and numerous innovative technologies, is the ultimate expression of all-electric sweeping.



Electric motors

Highly advanced, superior-performance and more energy-efficient motors.

Faster charging

AC charging on the new D.Zero² is faster thanks to the new On-Board charger, which reduce charging time.

Charging sockets

Equipped with COMBO CCS Type 2 and Type 1 socket to address the requirements of major markets.

Batteries

The new batteries with the latest Lithium-Iron-Phosphate cells not only reduces the weight of the machines but also offers a higher standard warranty coverage.

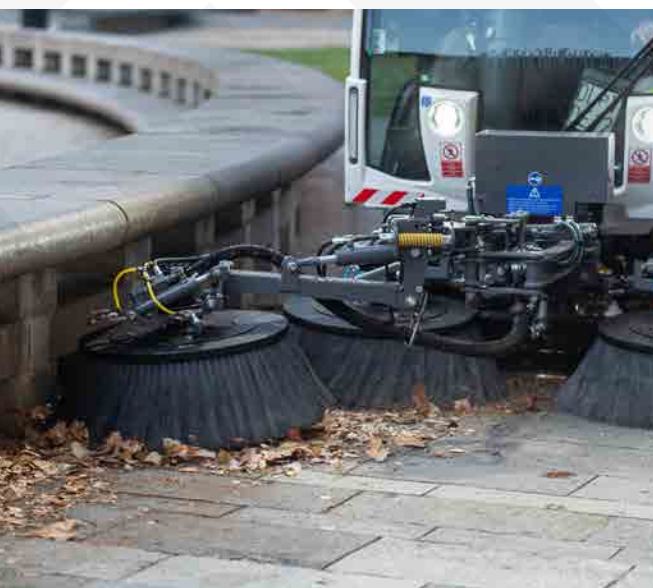

Charging points

The Combo version allows AC charging (charging points or Wall Box) and DC charging (external charger).

Reduced environmental impact

High-tech, electric motors for machines that respect people and the environment around them.

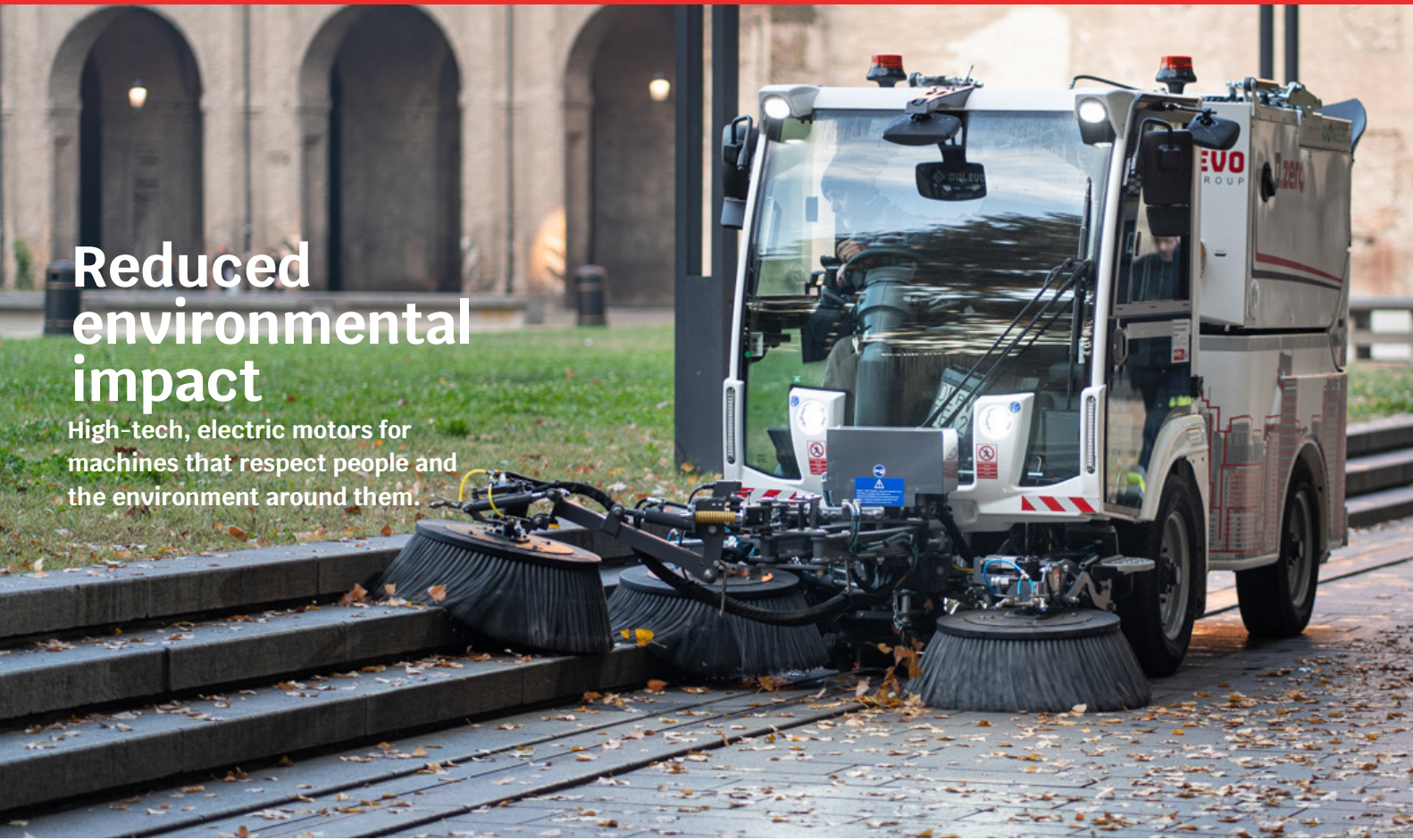

Decreased noise power

With 80% of the most common sweeping activities being carried out in ECO mode, the noise emissions are significantly reduced to be able to work at night for street cleaning without disturbing the peace.

Reduced water consumption

The wastewater recycling system fed back into the suction inlet significantly reduces the need for it.



Electric street sweeper

The electric street sweeper has zero CO₂ emissions with zero harmful gases emitted into the environment.

Dust control

A steel filter and a large water tank guarantee a reduction in dust.





Designed for people

Driving and working comfortably is more than just a luxury when operating a sweeper. The new cab has been designed to be comfortable and operator friendly even after many hours of work.



Relaxed driving

The ergonomic cab and great range of seat and steering column settings means that the driving position can be adapted to all body builds.

360° view

The large windscreen, glazed side doors, panoramic and wide-angle mirrors, rear panels, rear window for the intake nozzle and rear cameras provide an unsurpassed all-round view.

Multifunctional joystick.

The operator has full control of the sweeping functions. With the adoption of this innovative joystick, the concept of ergonomics and versatility have been significantly increased .

Control panel

Ergonomic and adjustable control panel layout and function displays according to the operator's needs.





Smart Thinking

Diagnostics and vehicle information are remotely accessible and can monitor the position of the sweeper, how it is used and any stoppages or breakdowns. Automatic service and maintenance is available.

CAN-BUS

In/Out communication system of sweeping and motor functions on CAN-BUS protocol.

Easy stop

All functions are deactivated, the suction mouth is raised and the brushes are lifted returning to the position (within the machine shape) of minimum clearance to move into transfer mode.

A.S.T.

Different work programs can be selected:

- ❖ ECO
- ❖ STANDARD
- ❖ HEAVY
- ❖ BOOST (for limited time of use)

Easy Start

At the push of a button, the sweeper is ready for work. For maximum efficiency, the machine is also equipped with an automatic stop system in case the sweeper is in a non-working position for a certain period of inactivity.

Machine operator interface

Diagnostics and vehicle information are remotely accessible. To monitor the position of the sweeper, how it is used and any stoppages or breakdowns. Automatic service and maintenance planning is also available.



The third-generation D.Zero² in brief:

Regulations EU 17106 Compliant. The machine was designed taking into account the new requirements demanded and defined for the safety of road surface cleaning machines.

New cab

The operator's comfort directly impacts productivity.

Container

The container can be opened in two ways for conventional dumping with or without compacting.

Fast Charge

The new version can be equipped with a new, more powerful and intelligent On-Board charger in addition to the two types of charging systems with external chargers.

Suction mouth

The inlet and its flap opening system are covered by a patent filed by Dulevo.

Batteries

The new lithium battery pack has been developed using the latest generation of cells available on the market.

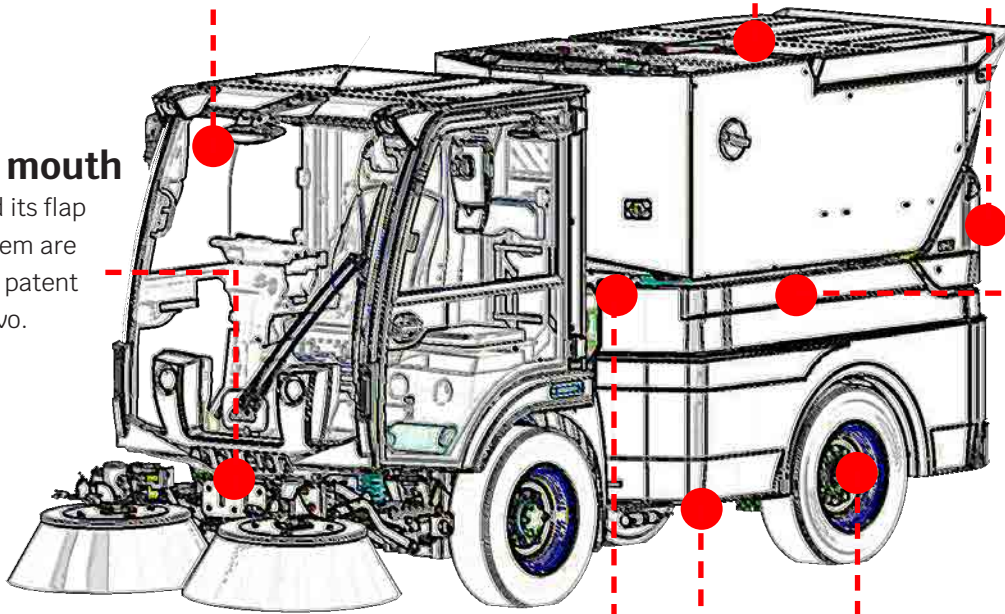

Suction hose

With a diameter of 200 mm (7,87 inches), it is installed in an outward, easy-to-inspect position without bends. For maximum performance, the coupling is through a spring-compensated flange.

Speed

The maximum speed 32km/h (20mph) of the vehicle is higher, reducing transfer times and increasing productivity.

Braking system

Greater speed requires greater safety and braking power. The new D.Zero² has an improved service and parking brake system.



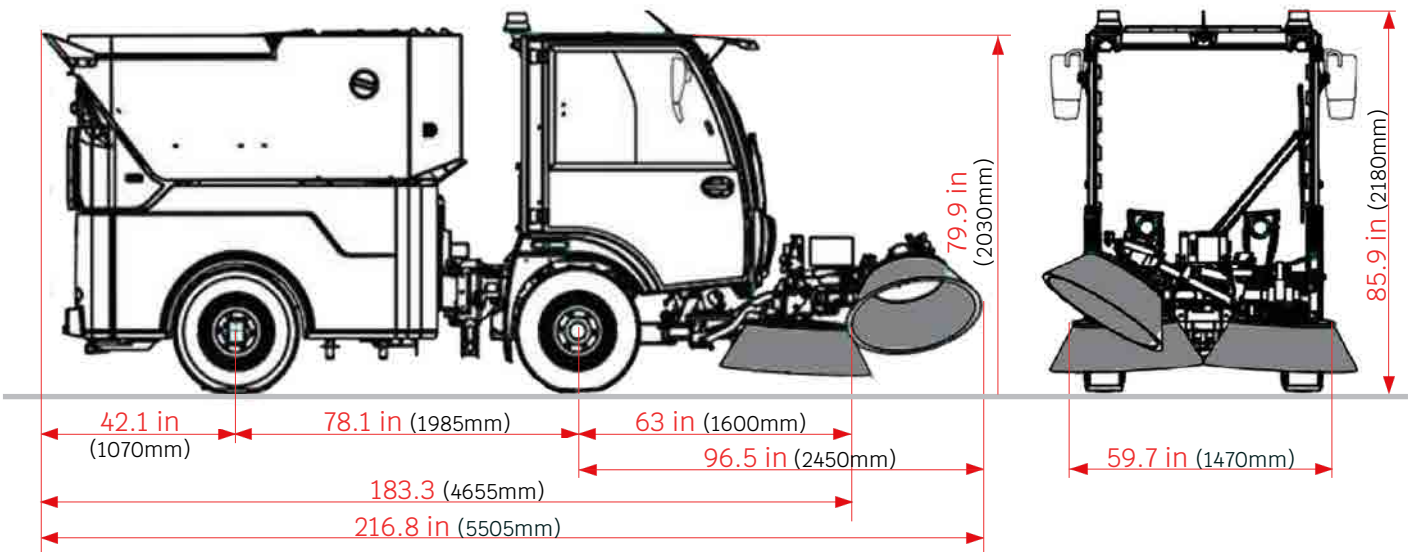

Technical Data

D.ZERO²

Sweeping width:		
- Minimum	in 69	mm 1.750
- Maximum	in 126	mm 3.200
- With third brush	in 134	mm 3.400
Waste container volume	yd ³ 1.6	m ³ 2
Height of container discharge	in 57	mm 1.450
Hourly output	ft ² /h 451920	m ² /h 42.000
Maximum speed	mph 20	km/h 32
Turning circle diameter (pavement)	ft 10.9	mm 3.300
Cab seats	n°2	
PM10 & PM2,5 Filtration EN 15429	EUNITED 4 Star	
Battery	KW/h75	

Applications*. A wide range of options and accessories, complementing its features, places the D.Zero² at the highest level for versatility and ductility.

- Third brush
- Side brushes inclination adjustment from the cabin
- HP washing system with gun and automatic reel
- Spare tire (not on board)
- Hydraulic Jack
- Reflecting stripes
- Wax film for sea freight
- Suction unit with hose Ø 3,9 In – Length 118 In



*Some pictures and equipment may show options that are not available in all markets. For information contact your nearest dealer: www.dulevo.com or info@dulevo.com

Dulevo Fayat Group

Dulevo was founded in 1976 and is now part of the Fayat Group, France's largest privately-owned construction, industrial and road infrastructure group. The knowledge of cleaning technology acquired by Dulevo, based in Parma in the heart of Italy's Motor Valley, forms the basis of our state-of-the-art and reliable machines. Our motto, 'Timeless Quality through Passion', reflects our commitment to providing innovative, high quality cleaning solutions to municipalities and industry, with a focus on environmental care.



Specifications are not binding for our company and subject to change at any time without notice.



Dulevo - Fayat Cleantech Americas
725A Imperial Court, Charlotte, NC 28273
www.dulevo.com/us

Dulevo International S.p.A.
Via Giovannino Guareschi, 1
43012 Fontanellato (PR) Italy
Tel: +39-0521-827711
www.dulevo.com

QUALITY, INNOVATION AND RESPECT FOR THE ENVIRONMENT
Dulevo Certifications:



EUnited PM TEST
COLLECTION AND
FILTRATION
DUST

